



## POWER INFRASTRUCTURE MONITORING SYSTEM ON EMBEDDED WEB

Gambhir Jayant H., & Wani Lalita K.  
Siddhant College of Engineering, Pune, India

### ABSTRACT

The PIMS system is needed for monitoring of power being used by remote equipment such as cell tower. The PIMS agent consisting of high resolution ADC and microcontroller monitors the current and voltages being consumed and sends the data over GPRS to the centralized server. The server collects the data, stores it in database and uses it for analysis. The monitoring helps to determine the power use as well as it also enables the user to identify the malfunction of the system remotely.

**KEYWORDS:** PIMS, Embedded server, GPRS, RMS value

### INTRODUCTION

Now requirement of remote monitoring is increasing for Sensing and Managing of temperature, voltage, current and such parameters. To obtain effective way of monitoring by using microcontroller based technology and internet web pages. In comparison with PC, the embedded system is greatly improved in stability, reliability and safety etc. The embedded system transplanted web server can be called embedded web server. Through web page released by embedded web server, remote users can obtain the real-time status information and control remote equipment without time and space restriction. This type of Embedded Web Server has many advantages, such as small size, low power consumption, low cost and flexible designed. It's easy to implement, and it is an effective way of leading Internet into embedded system. The embedded device communicates through General Packet Radio Service (GPRS), which makes it accessible from anywhere in the world through a web server built into the embedded device. Each cell-site tower is equipped with a Power Management System. Each communication server is connected to the GPRS / CDMA network service provider via a leased line. Asynchronous events / alarms that occur at the PMS are received and processed by the communication server.[3][4]

### LITERATURE REVIEW

An Embedded web server which controls and monitors the remote devices has the advantages over the traditional monitoring system which are based on the PC and chip microprocessor.

**Remote monitoring system based on chip microprocessor [1]** The chip microprocessor transplanted TCP/IP protocol is configured to an embedded web server which has data collection, storage and communication functions. The method can reduce development cost, but at the same time, it brings some difficulties in functional upgrading and expansion.

PC-based remote monitoring system [1] PC is the central part of remote monitoring system. The design can shorten

the development cycle with the help of mature development tools on the PC platform. But it has some drawbacks as high cost, unsatisfactory stability and reliability. Moreover in the Client/Server architecture, the maintenance burden on the server would be heavy because some particular monitor software should be installed on each remote monitor terminal. In various Internet applications based on client server architecture, it is better to use embedded WEB server other than PC server for decreasing volume, cost and power consumption.

Remote monitoring system based on embedded web server[1][2] Through Embedded Web Server System we can connect any electronic device to web server and can get the real time data of devices through the web pages released by the server. The method can overcome the problem of PC based monitoring system.

### SYSTEM ARCHITECTURE

The proposed system is divided into two parts viz. PIMS agent and centralized embedded server. The PIMS agent is equipped with microcontroller based system monitoring the current and voltage being used by equipment (load) all the time. The collected data is sent over GPRS in real time to the embedded server. The embedded server keeps all the data in database and uses it for further actions like notification for any abnormal operation, power failure etc. The general system architecture is shown in fig. 1

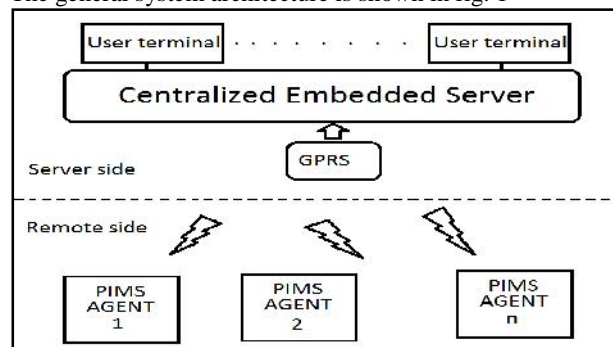

Fig 1. System Architecture

Fig. 1 show the Block Diagram PIMS System, GSM and GPRS are developed for cellular mobile communication. A GPRS connection with unlimited duration of connectivity is changed only for the data package transfers and adopted in several mobile remote control/access systems. GPRS becomes a cost – effective solution only if the data transfers can be optimized. At the Centre a server with suitable software to handle internet and a huge database is used and a provision for sending EMAILS on a given address as per the product is sent for immediate action so that no operator is required at the server Centre. The framework is based on GPRS data connectivity between the PIMS communication server and the PIMS agents with the entire communication being TCP/IP based. An application based protocol framework is present for message exchange between the WPIMS communication server and the WPIMS agents. Messages are defined for event reporting, health & status information, and control operations.

### The PIMS agent

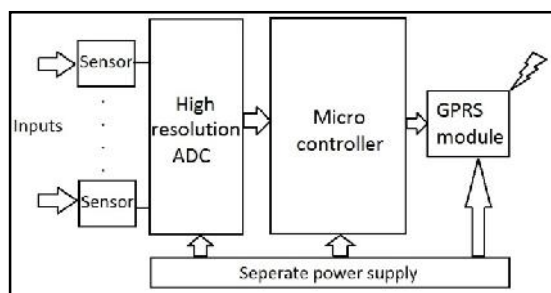

Fig 2. Typical PIMS agent

As shown in fig. 2 PIMS agent which can monitor a given product by using the best and reliable mode of communication from the site to the central monitoring point in case occurrence of any abnormalities in the product or after a period specified by the user of the system. The PIMS runs on a separate power supply independent of the target equipment. The sensors for the PIMS agent depends on the parameters to be monitored. For our system, we need current and voltage sensor to monitor power. The detailed connections for current and voltage measurements are shown in fig.3

A low power consumption microcontroller MSP430F673x is suitable for this system as it has internal 24 bit ADC. To some degree or another, most sensor outputs are non-linear with respect to the applied stimulus, and as a result their outputs must often be linearized in order to yield correct measurements. Analog is one viable route, and such techniques may be used to perform an “analog domain” linearization function. However, the recent introduction of high performance ADCs now allows linearization to be done much more efficiently and accurately in software. This “digital domain” approach to linearization eliminates the need for tedious manual calibration using multiple and sometimes interactive analog trim adjustments. Every site is added with a client unit which collects data from the product and identifies the abnormalities and communicates with the Centre via GPRS link on GSM/GPRS MODEM the Centre is having internet connection with static IP and

number of such clients can communicate with the many number of Centre. The way of embedding the Web server in the device makes it possible

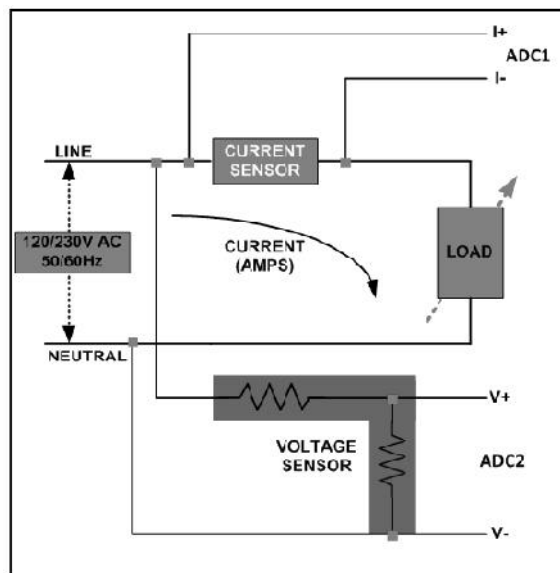

Fig 3. Current & voltage measurement

for numerous embedded devices to be connected to the Internet The results of system performance testing show that the system can meet most of the embedded Internet applications demands and the purposes of online access, control and management the embedded devices using a standard Web browser over the Internet can be realized.

### The GPRS module

The general packet radio service (GPRS) is a packet-oriented mobile data service used in 2G and 3G cellular communication systems global system for mobile communications (GSM).The proposed system uses a GPRS-Modem as a communication device to transmit time, date, physical location and level of air pollutants. The modem used for the proposed system has an embedded communication protocol that supports Machine-to-Machine (M2M) intelligent wireless Transmission Control Protocol (TCP/IP) features such as Simple Mail Transfer (SMTP) E-mail, File Transfer Protocol (FTP), and Simple Messaging Service (SMS) services Protocol. The modem supports an RS-232 interface that allows Serial TCP/IP socket tunneling. The modem also has rugged aluminum enclosure making it suitable for the proposed system [8].

### SYSTEM IMPLEMENTATION

The implementation starts with the PIMS agent. The initialization routines involves the setup of the analog to digital converter, clock system, general purpose input/output (GPIO) port pins, timer, LCD and the USCI\_A1 for universal Asynchronous receiver/transmitter (UART) functionality. A check is made to see if the main power is OFF and the device goes into LPM0. During normal operation, the background process notifies the foreground process through a status flag every time a frame of data is available for processing. This data frame

consists of accumulation of energy for 1 second. This is equivalent to accumulation of 50 or 60 cycles of data samples synchronized to the incoming voltage signal. In addition, a sample counter keeps track of how many samples have been accumulated over the frame period. This count can vary as the software synchronizes with the incoming mains frequency. The data samples set consist of processed current, voltage, active and reactive energy. All values are accumulated in separate 48-bit registers to further process and obtain the RMS and mean values. The overall foreground process may be summarized as shown in fig.4 .

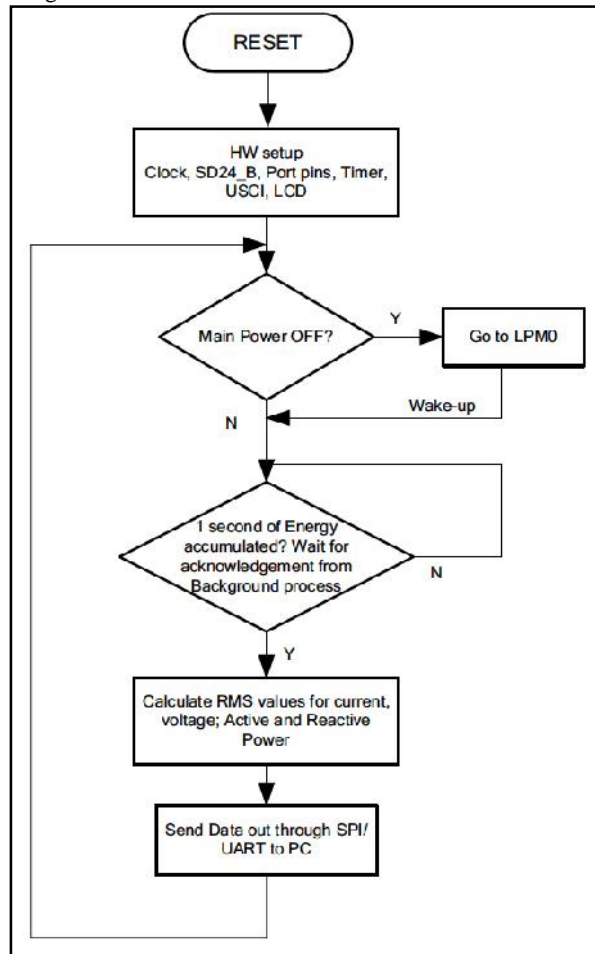

Fig.4 Flowchart of process

**FORMULAE**

• **Voltage and Current**

The simultaneous voltage and current samples are obtained from three independent ΣΔ converters at a sampling rate of 4096 Hz. Track of the number of samples that are present in 1 second is kept and used to obtain the RMS values for voltage and current for each phase.

$$V_{RMS} = K_v * \sqrt{\frac{\sum_{n=1}^{Sample\ count} v^2(n)}{Sample\ count}}$$

$$I_{RMS} = K_i * \sqrt{\frac{\sum_{n=1}^{Sample\ count} i^2(n)}{Sample\ count}}$$

v(n)= Voltage sample at a sample instant ‘n’  
 I(n)= Current sample at a sample instant ‘n’  
 Sample count= Number of samples in 1 second  
 Kv = Scaling factor for voltage  
 Ki = Scaling factor for current

• **Power and Energy**

Power and energy are calculated for a frame’s worth of active and reactive energy samples. These samples are phase corrected and passed on to the foreground process that uses the number of samples (sample count) and use the formulae listed below to calculate total active and reactive powers.

$$P_{ACT} = K_p * \frac{\sum_{n=1}^{Sample\ count} v(n) * i(n)}{Sample\ count}$$

$$P_{REACT} = K_p * \frac{\sum_{n=1}^{Sample\ count} v_{90}(n) * i(n)}{Sample\ count}$$

v90 (n) = Voltage sample at a sample instant ‘n’ shifted by 90°

Kp = Scaling factor for power

The consumed energy is then calculated based on the active power value for each frame in similar way as the energy pulses are generated in the background process except that:

$$E_{ACT} = P_{ACT} * Sample\ count$$

For reactive energy, the 90° phase shift approach is used for two reasons:

- This allows us to measure the reactive power accurately down to very small currents.
- This conforms to international specified measurement method.

**DEVELOPMENT OF THE WEB BASED SYSTEM**

The parameters sent over GPRS network are collected by centralized server on real time basis. The server application is developed using C#. The database is able to store the real time parameters for about past 6 months and analyze it to display the power consumption as per the consumer’s need.

**THE KEY FEATURES[4]**

1. Based on distributed architecture (for scalability)
2. Instantaneous notification to the PIMS central server.
3. Logging the occurrence and clearing of all fault /alarm conditions.
4. Modular scalability – The PIMS is designed to ensure that that the system is scalable in a modular fashion.
5. Standard TCP/IP based connectivity.
6. Visual overview of the status and health of all PMS at the PIMS central system.

7. Remote Control functions – the system can be extended to carry out control functions from the NOC on a selected PMS
8. Database to analyze past data.
9. Reports generation

### CONCLUSION

The system adopts Browser / Server mode and realizes the interconnection of the embedded devices. Therefore, remote users can access, control and manage the embedded devices using a standard Web browser over the internet. It has advantages of small size, longer work time and stable performance. It is easier, flexible, and more user-friendly. The greatest benefit to Embedded Internet of Embedded Web Server (EWS) is without a doubt the availability of a standard connection to the outside world. There are some technologies, which provide solutions to the wireless data transmission network, such as: GSM, CDMA, 3G, and Wi-Fi. These solutions make network work with high efficiency and good quality, but still with high cost, so wider application would cause a great waste of resources, and they cannot be promoted in small regional and low speed data communication.

### REFERENCES

- [1] Srinivas Raja, G. Srinivas Babu, “Design of Web based Remote Embedded Monitoring system” International Journal of Technology and Engineering system(IJTES),Jan-March 2011-Vol.2,No.2.
- [2] Fang Hongping, Fang KangLing, “The Design of Remote Embedded Monitoring System based on Internet” International Conference on Measuring Technology and Mechatronics Automation,,2010.
- [3] B.S.Deore,N.S.Dawande “Wireless power infrastructure monitoring system” International Journal of Advanced Research in Electrical, Electronics and Instrumentation Engineering (IJAREEIE) Vol 2, Issue7, July2013
- [4] Mr Ajay K. Kakde, Mr Ajay P. Thakare “Power Infrastructure Monitoring System on Embedded Web” International Journal of Scientific & Engineering Research ISSN 2229-5518, Volume 2, Issue 6, June-2011
- [5] Yong-tao ZHOU, Xiao-hu CHEN, Xu-ping WANG, Chun-jiang YAO, “Design of Equipment Remote Monitoring System Based on Embedded Web”, IEEE International Conference on Embedded Software and Systems Symposia, pp 73-78, 2008.
- [6] Ali ZiyaAlkar, “An Internet Based Interactive Embedded Data- Acquisition System for Real-Time Applications”, Journal: IEEE Transactions on Instrumentation and Measurement, vol. 58, no. 3, pp. 522-529, 2009.
- [7] Igor Klimchynski “Extensible Embedded Web Server Architecture for Internet-Based Data Acquisition and Control” IEEE SENSORS JOURNAL, VOL. 6, NO. 3, pp.804-811, JUNE 2006
- [8] GPRS-Modem Technology. [Online]. Available: <http://www.comtechm2m.com/gprs-modem/gsm-gprs-modem.htm>